

Electric Power Research Institute (EPRI) Perspective on Advanced Sensing Needs

Ron Schoff

Director, Renewable Energy and Fleet Enabling Technologies, EPRI

Ron Schoff

Director, Renewable Energy and Fleet Enabling Technologies, EPRI



Ron Schoff is the Director of the Renewable Energy and Fleet Enabling Technologies area at the Electric Power Research Institute (EPRI).

The Renewable Energy and Fleet Enabling Technologies research area is focused on:

- Assessing the performance, cost and market economics of renewable generating technologies, primarily wind, solar, and hydropower.
- Conducting targeted RD&D to address critical issues relative to the technical assessment, operation, maintenance, and overall reliability of renewable generation assets.
- Improving environmental performance of renewable generation facilities with focus on siting and permitting, wildlife impacts, human impacts, and end-of-life disposal and recycling opportunities.
- Materials and non-destructive evaluation research supporting all energy supply asset types.
- Integrated asset management, plant management and digital worker support, helping asset owners and managers improve performance at lower cost.
- Digital transformation scope, including cyber security, sensors and advanced data, automation and controls and artificial intelligence R&D.

Prior to his current role, Schoff led EPRI's Technology Innovation program, which focuses on industry thought leadership; scouting emerging technologies through engagement with universities, technology incubators and startups; and collaborative, early-stage research.

Schoff holds a Bachelor of Science degree in chemical engineering from the University of Pittsburgh and a Master of Science degree in chemical engineering from Villanova University. He has published numerous papers and given talks at various technical conferences worldwide.

Dynamic Energy Landscape: Role of Data

Ron Schoff, Director
Electric Power Research Institute

University of Pittsburgh Infrastructure Sensing
Collaboration Workshop
August 25, 2022



EPRI

Leading Collaborative Energy R&D Around the World

EPRI advances energy technologies and informs decision-making through ~\$420M in collaborative annual research involving nearly 400 entities in ~40 countries - spanning the generation, delivery, and use of electricity.



ENGAGING

- Utilities
- Academia
- OEMs
- Regulators



LISTENING

- Financial Community
- Policy Makers
- Consumer Advocates
- Media

ENERGY TRANSFORMATION

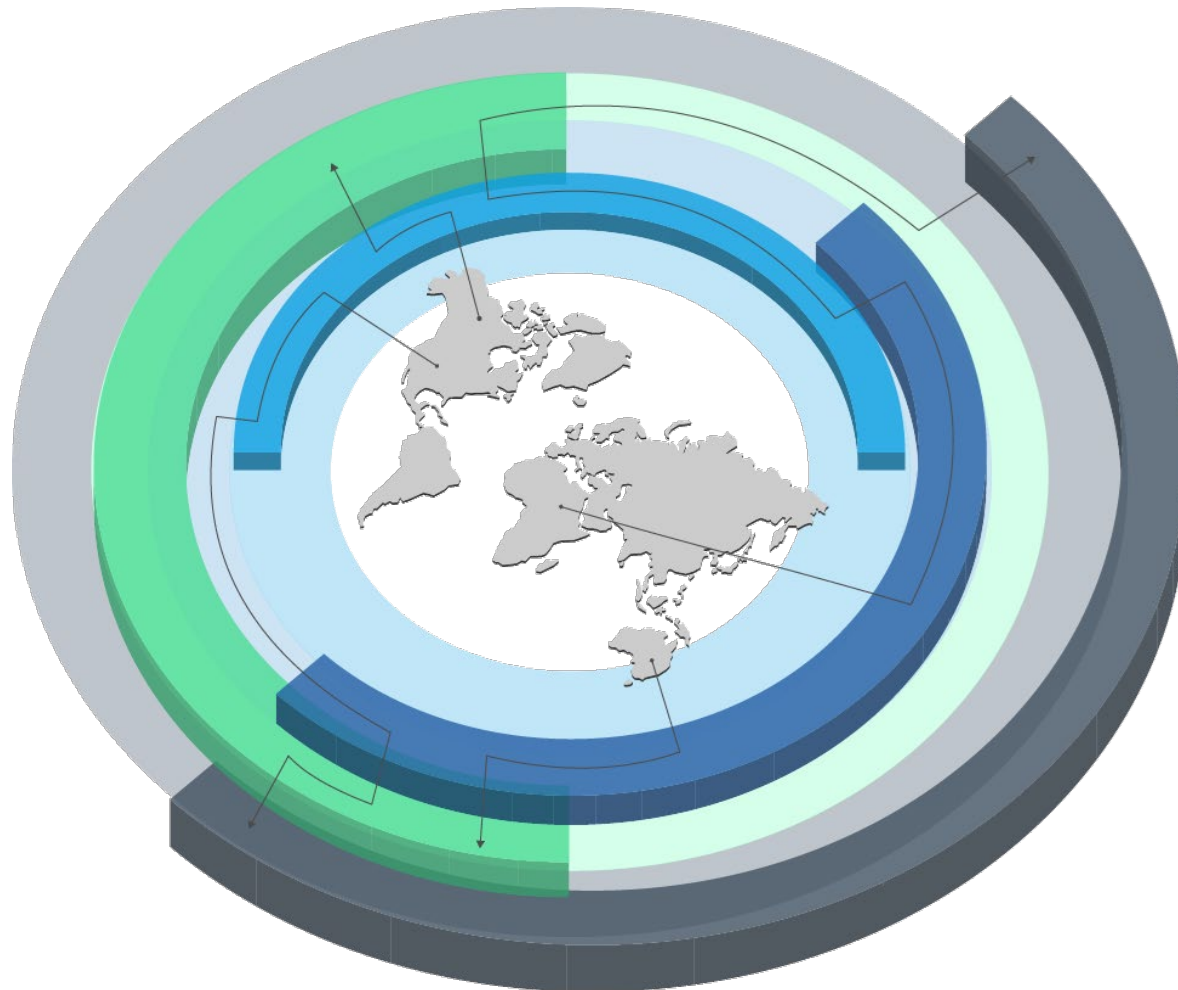

EXPAND ENERGY SUPPLY ASSETS FOR TODAY AND TOMORROW

Ensuring low-cost access to energy
Regional mix based on available resources
Evolving as societal priorities change over time



EVOLVE ENERGY SUPPLY CAPABILITIES

Efficiency and reliability driven by societal needs
Flexibility and security growing priorities
Consumer engagement with the energy system



DEVELOP CLEAN ENERGY SOLUTIONS FOR COMMUNITIES AND THE ENVIRONMENT

Air, land, water, and wildlife resources
Public health and safety
Environmental equity and justice



ACCELERATE LOW-CARBON TECHNOLOGY DEVELOPMENT AND ADOPTION

Implementing economy-wide carbon reduction strategies
Enabling low/zero-carbon technologies
Transitioning assets, networks and systems
Growing need for energy system resiliency

PAST 15 YEARS

Electric Sector Leading maintaining affordability & reliability

2005 2010 2015 2020 2025 2030 2035 2040 2045 2050

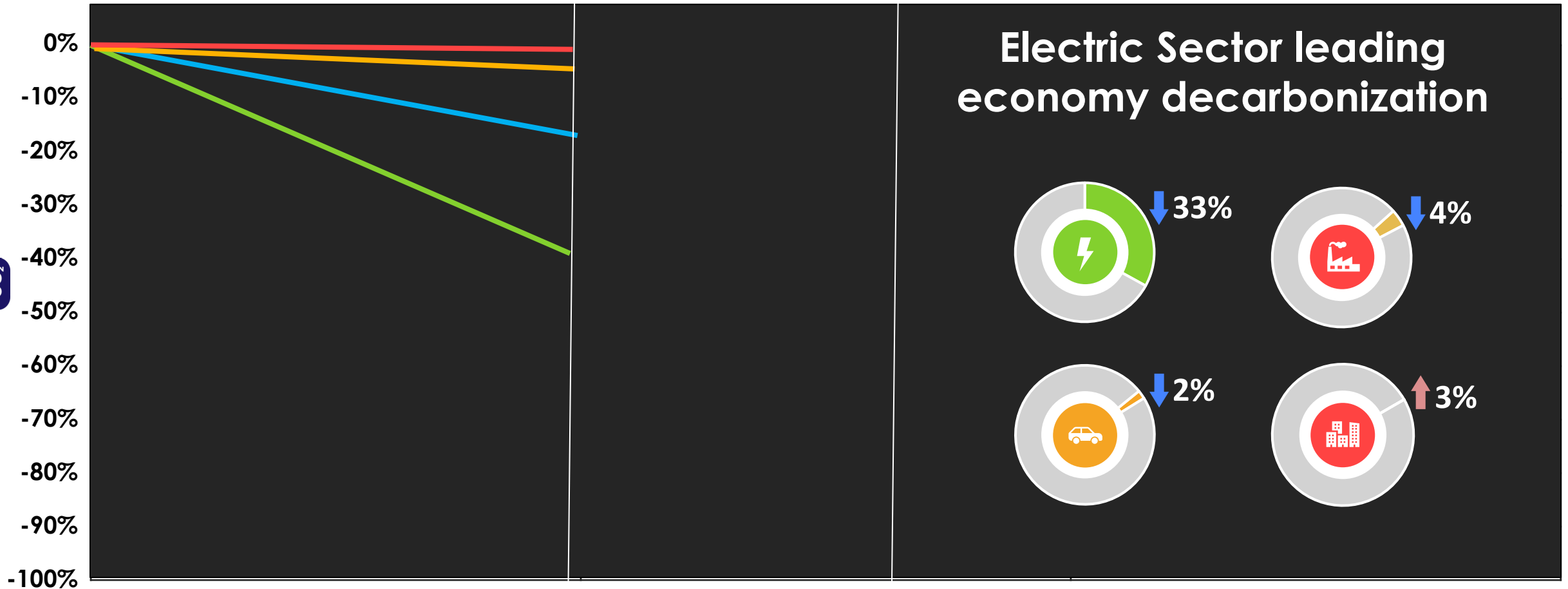

Electric Sector leading economy decarbonization

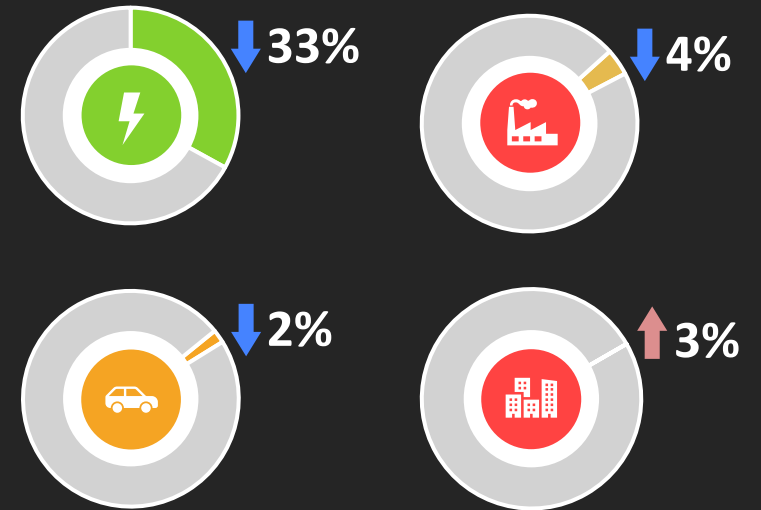

Economy-Wide

Electric Sector

Transportation

Industry & Buildings

THIS DECADE

Pathway to 50%
electric sector continues to lead

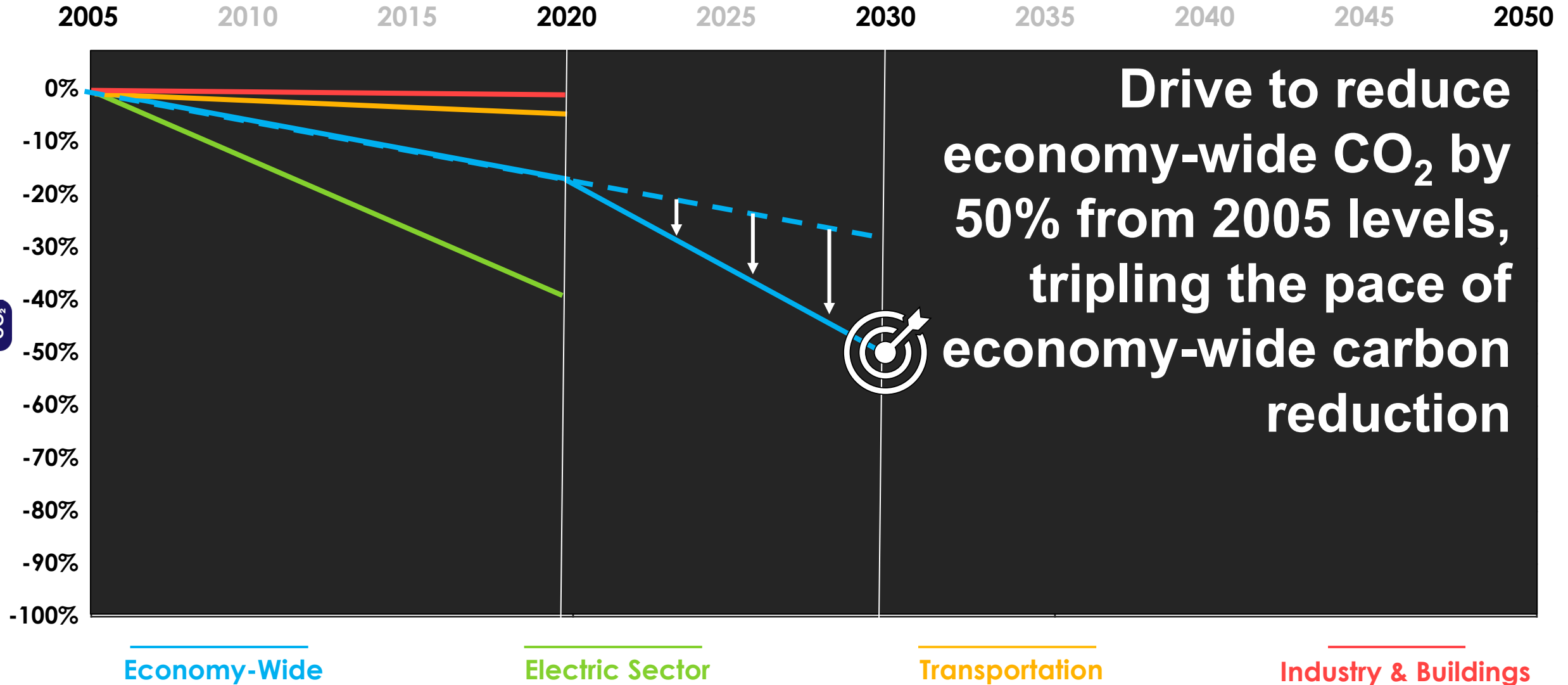

THIS DECADE

Pathway to 50%
electric sector continues to lead

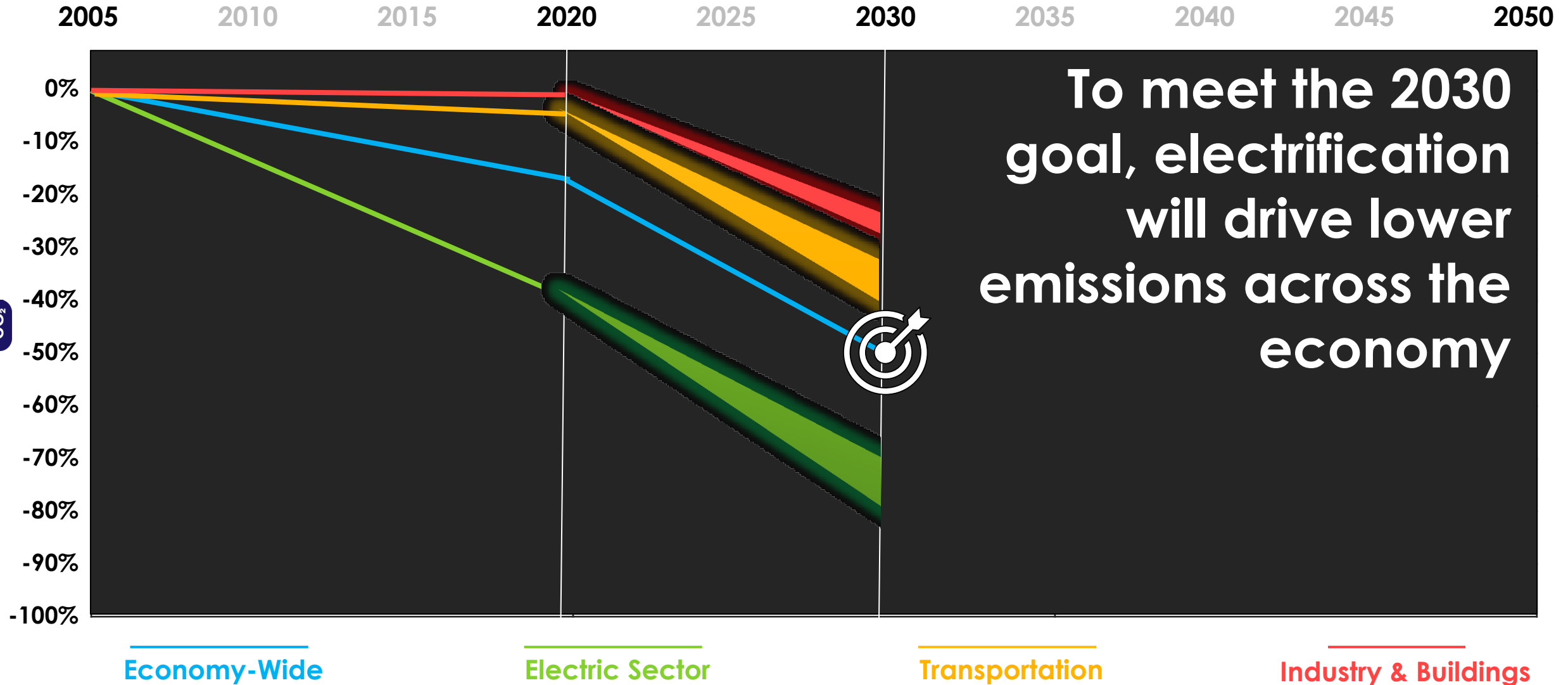

To meet the 2030
goal, electrification
will drive lower
emissions across the
economy

BEYOND THIS DECADE

Pathway to Net-Zero more technology needed

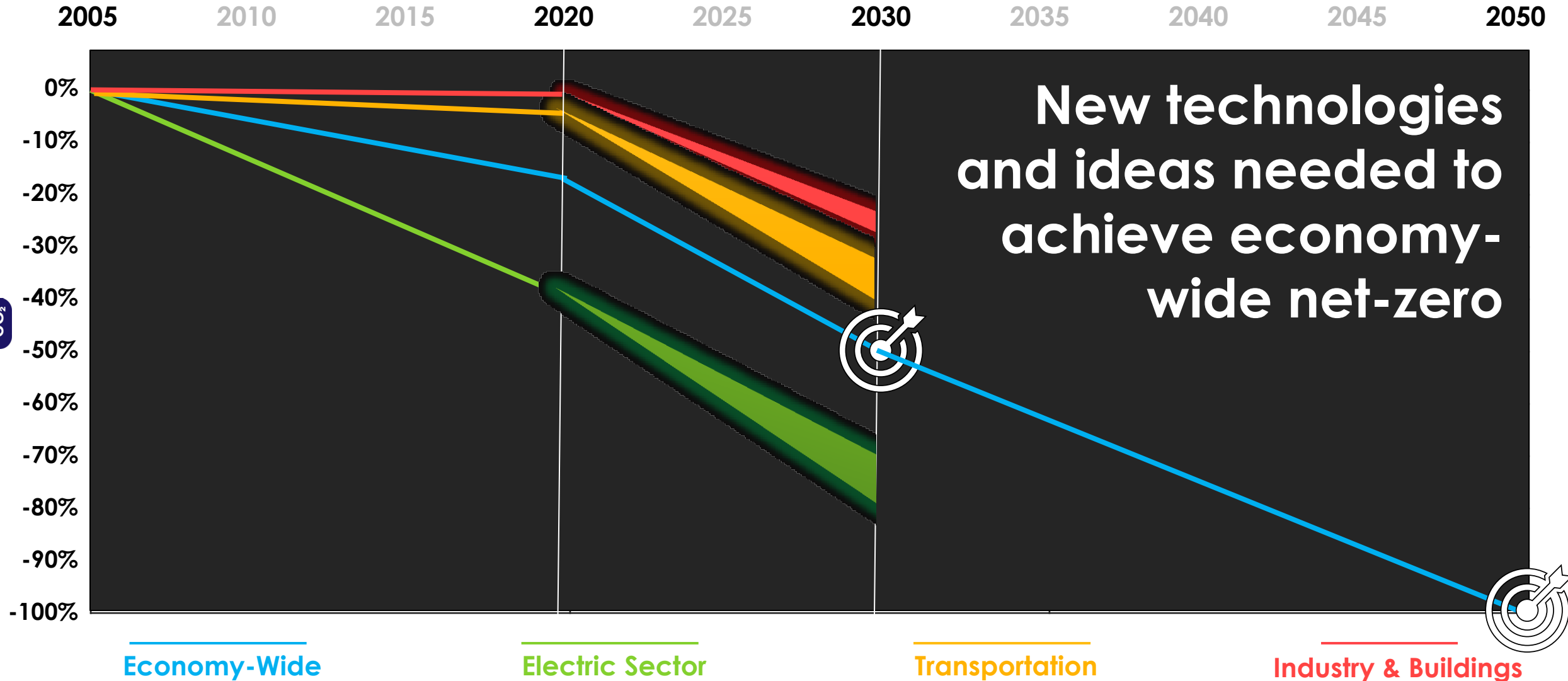

BEYOND THIS DECADE

Pathway to Net-Zero
more technology needed

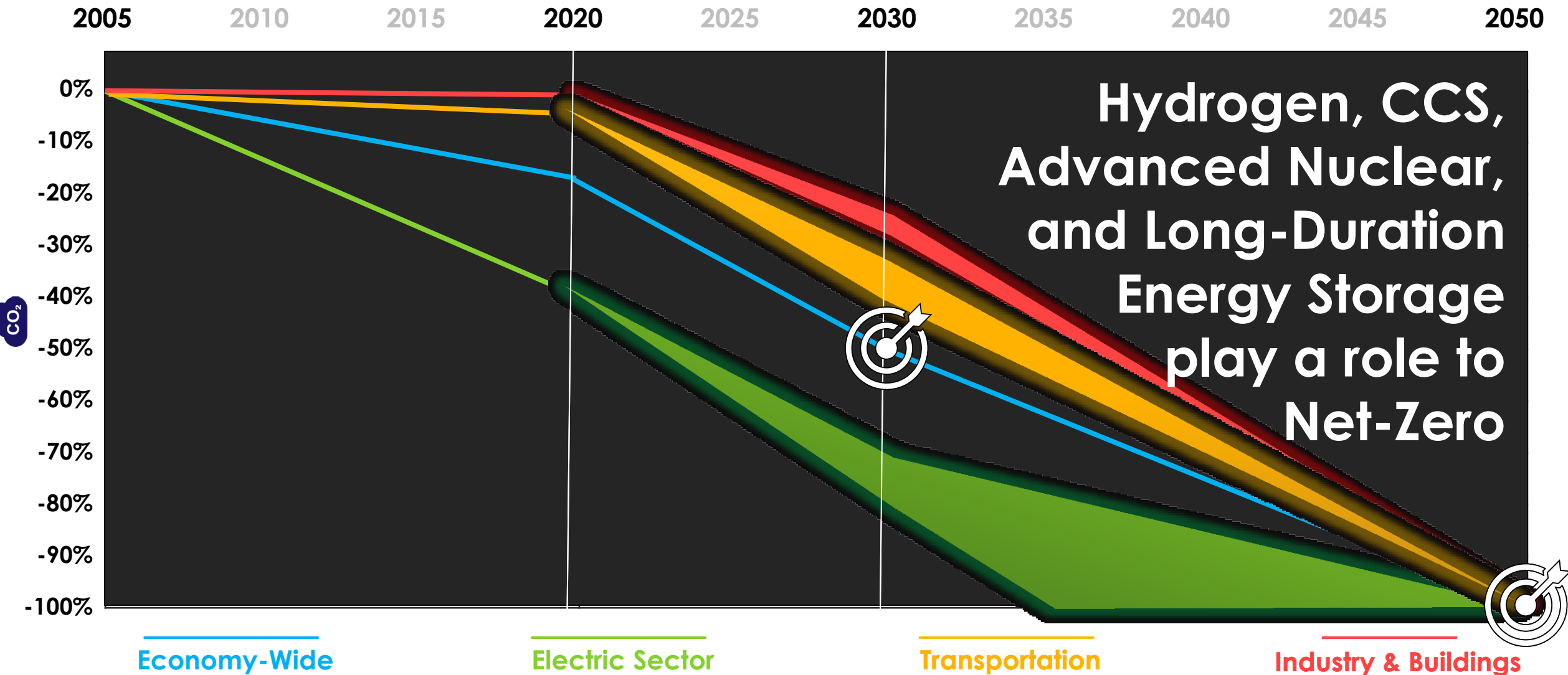

WHAT WILL 2050 LOOK LIKE?



What are the technologies?



What value do they provide?



What will they cost?



How will they perform?



What are the barriers to overcome?



Decarbonization

Digitalization

Decentralization

Digital Transformation is an enabler to Energy Transformation
Data is foundational to Digital Transformation
Sensors are primary data collection devices and sources

Energy Supply Fleet Management

Focused on achieving better outcomes throughout the energy transformation

Performance



Leveraging data and information to improve equipment and personnel performance at a fleet level

Reliability and Resiliency



Ensuring equipment reliability and asset health is critical to meeting variable energy demand and critical dispatchability

Operational Efficiency

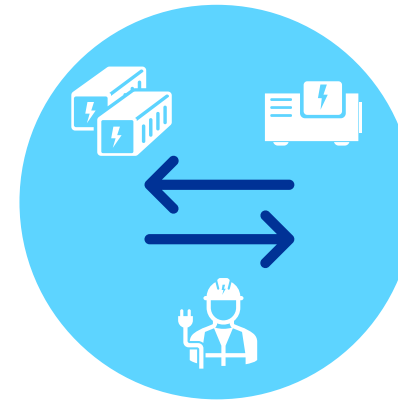

Connecting and integrating data streams and business functions to improve human performance and asset operations

Security



IT and OT integration with more IT equipment in the DCS and shared responsibilities for maintaining and securing equipment

Digital transformation and data are foundational to actionable outcomes.

Challenges and Digitalization Solutions

Energy Transformation Challenges

- Flexibility requirements
- Resiliency needs
- Renewables integration
- Tightening O&M budgets
- Workforce transition
- Increasing environmental requirements



Digitalization Enablers



DATA-CENTRIC
STRUCTURE



INFORMATION
PROTECTION



ANALYSIS AND
ALGORITHMS



INDUSTRY-WIDE
BENCHMARKING



COLLABORATION &
DEMONSTRATIONS

Physical Assets

- Net Zero
- Plant Optimization
- Pressure Parts and Materials
- Renewables
- Rotating Equipment
- Water and Land



Digital Technologies

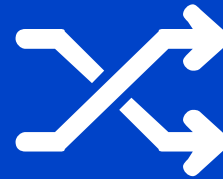

- Data Collection & Utilization
- Centralized Analysis
- Cybersecurity
- Advanced Automation
- AI + Machine Learning
- Digital Worker
- Digital Twin

Fleet, Plant, and Asset Management



- Performance Optimization
- O&M Management
- Workforce Transition
- Resiliency and Sustainability

Data

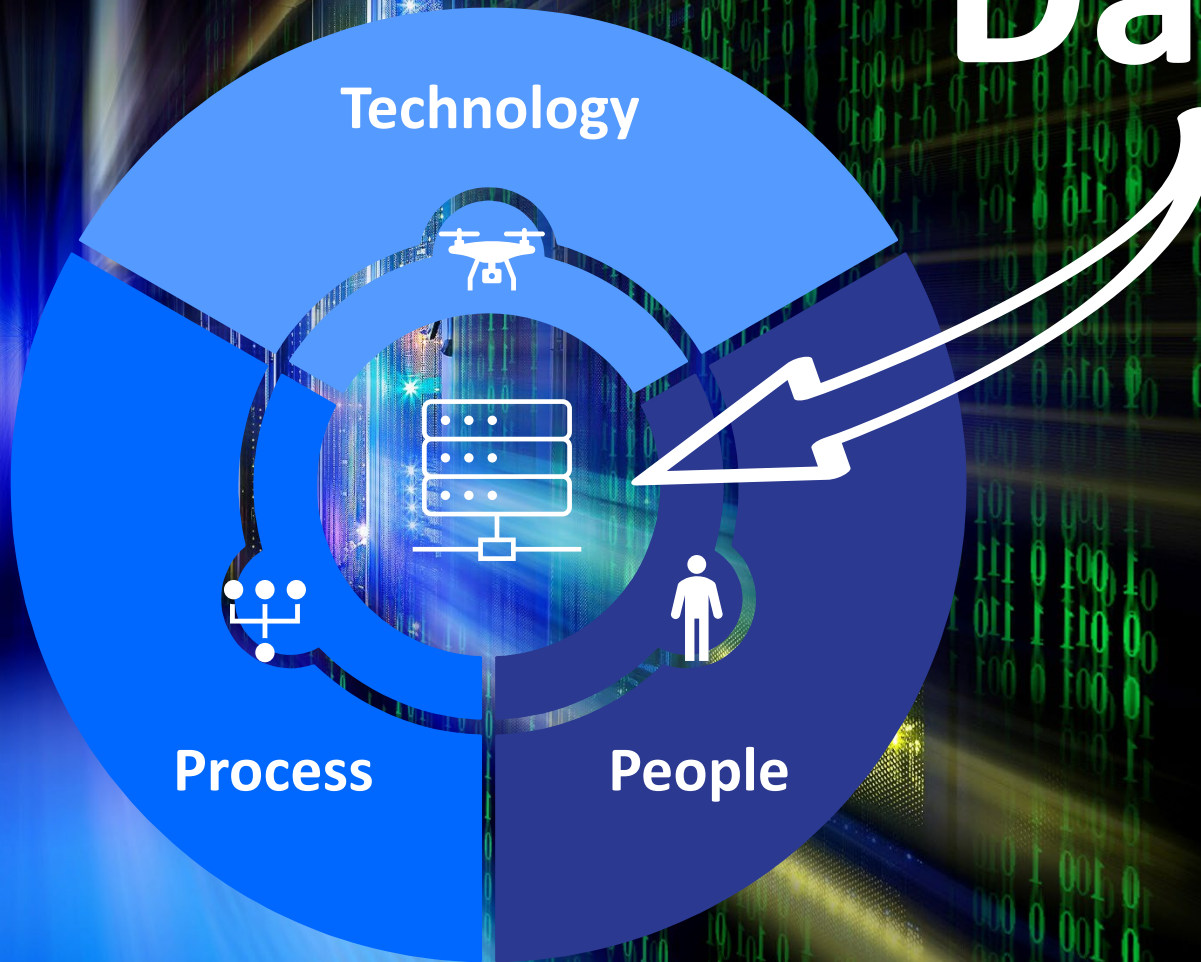

Data

- Sources
- Collection
- Integration
- Contextualization
- Staging
- Analysis
- Visualization
- Connectivity
- Governance

Data is a primary, permanent asset; applications come and go

Intentional Data Collection

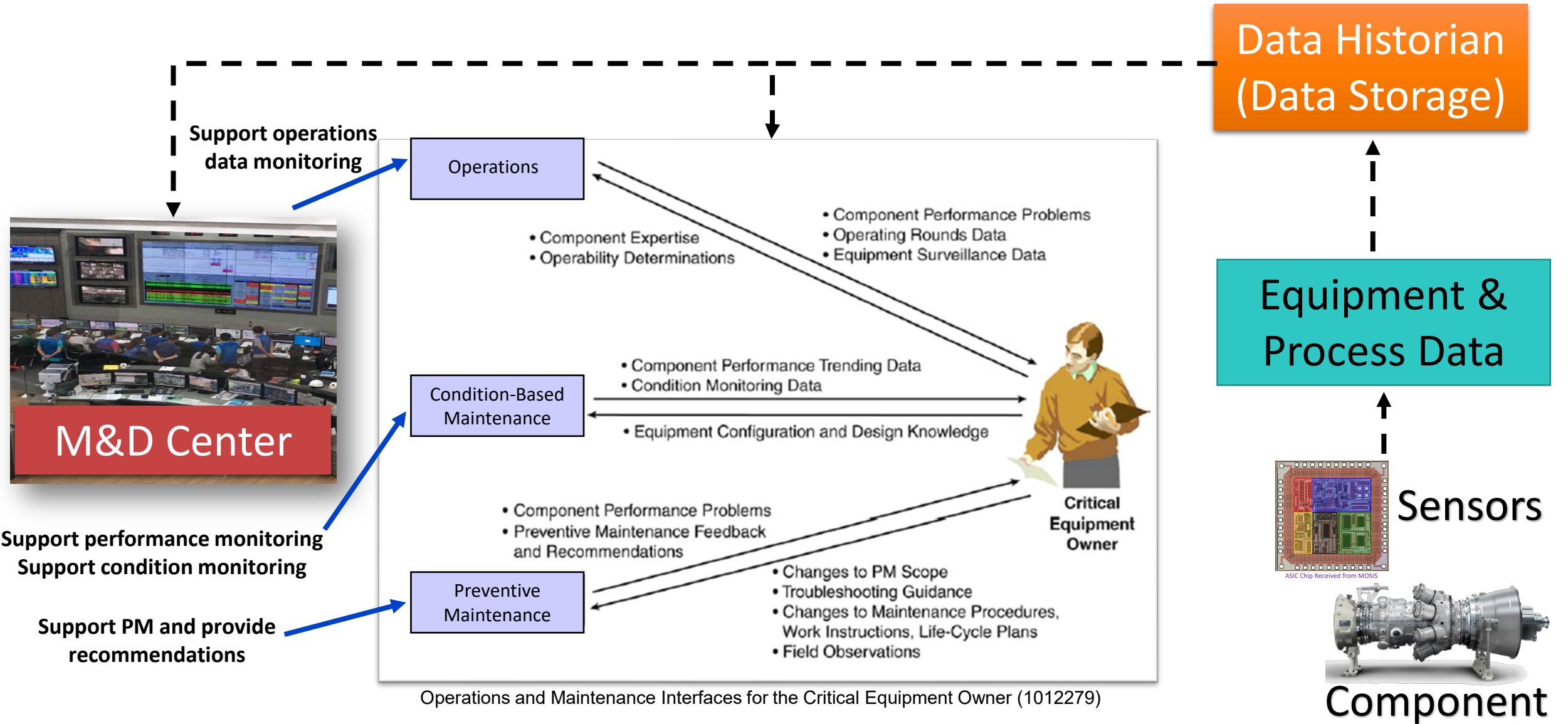

Example: Fault Driven Intentional Data Collection Via Sensors

Sensor No.	Sensor Technology	Sensor No.	Sensor Technology
1	Acoustic sensor - Gear box	13	Tri-axial Accelerometer - Motor outboard
2	Acoustic sensor - Motor	14	Tri-axial Accelerometer - on Gearbox at Motor side
3	Automated level sensor	15	Tri-axial Vibration Sensor – End-winding
4	IR Camera - Motor	16	Tri-axial vibration sensor - On Gearbox at Fan side
5	Oil Pressure - gearbox	17	Tri-axial vibration sensor Gearbox base
6	Partial Discharge Analysis	18	MCSA
7	Temperature sensor- Gearbox bearings	19	Tri-axial vibration sensor - Shroud
8	Temperature Sensor - Winding	20	IR Camera - gearbox
9	Temperature sensor- motor bearings	21	PH meters
10	Tri-axial Accelerometer - Motor base	22	Triaxial Vibration sensor - Structural
11	Tri-axial Accelerometer - Motor housing	23	Triaxial Vibration sensor - Stairs and Walkways
12	Tri-axial Accelerometer - Motor inboard		

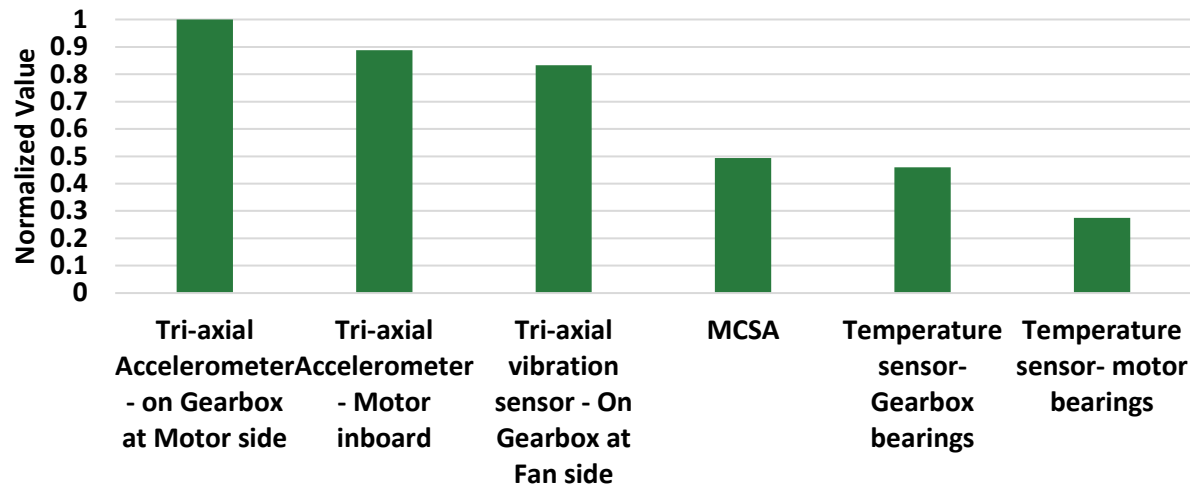
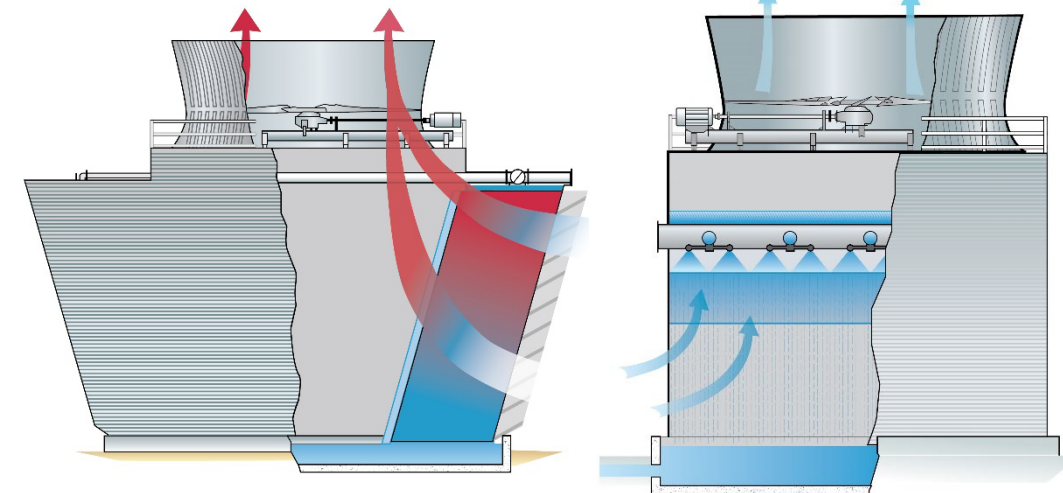
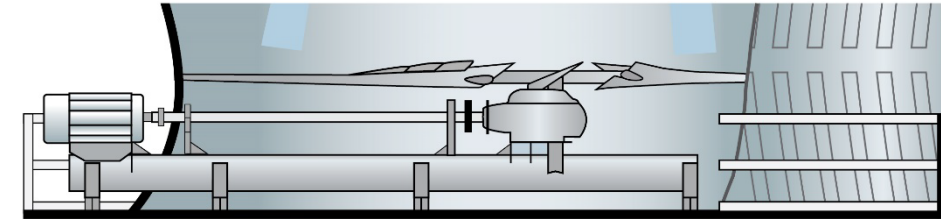

Intentional Data Collection Informed by Diagnostics

Building Asset Fault Diagnostics

- Leverage Time Series (i.e. On line sensors) and Static Data Sources
- Leverage Digital Twins and other models
- Leverage AI/ML/Analytics

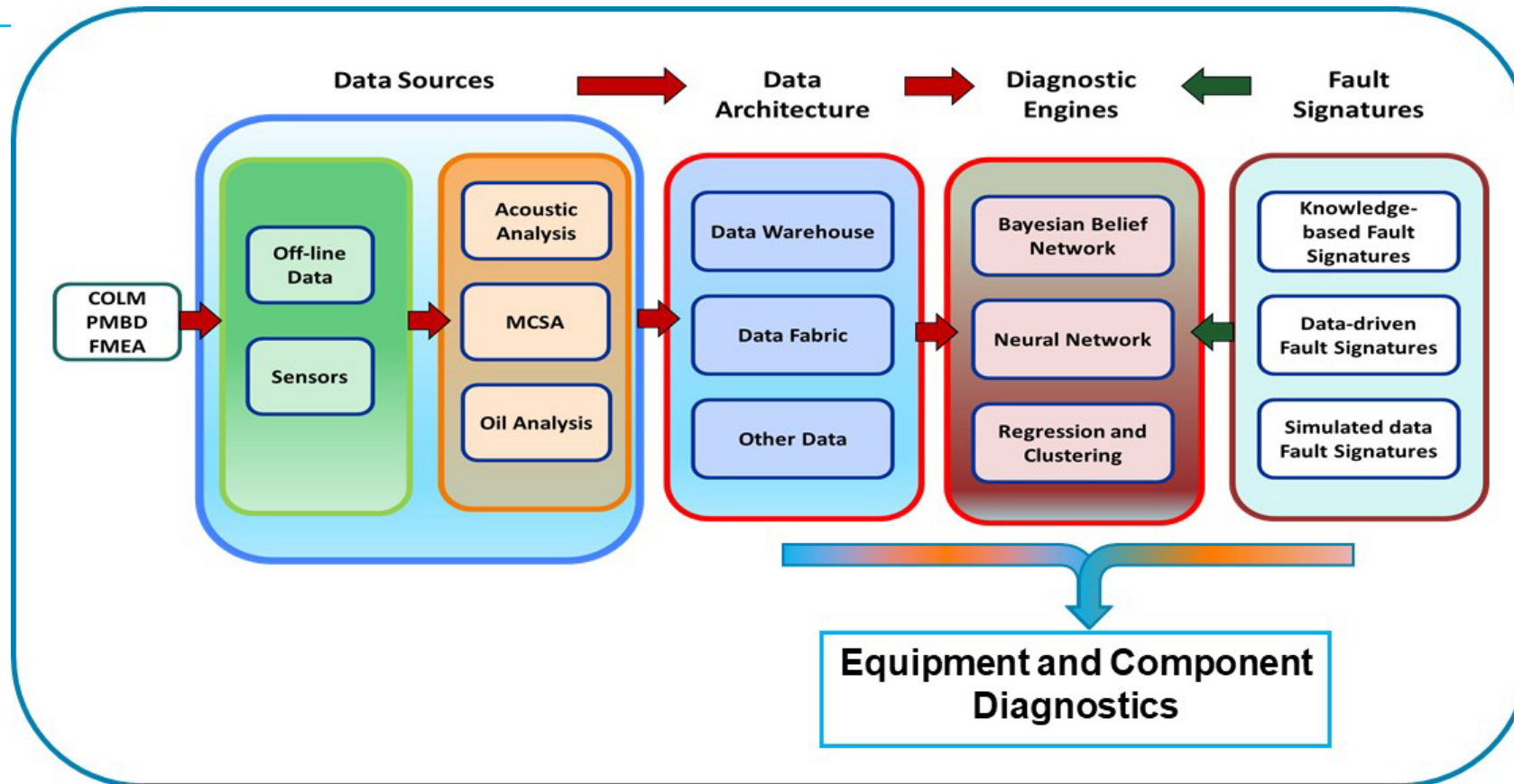

Sensor Maturity - Power Generation Perspective

OFFLINE & ONLINE MEASUREMENT

- Basic Point Measurements
- Visual observation of condition

EXPANDED ONLINE MEASUREMENTS

- Increased number and type of sensors
 - Performance and compliance monitoring
 - Equipment & component condition
- Wireless sensor Development
- Inferential sensing

PERVASIVE SENSING

- Low cost wireless sensors
- Highly distributed sensing
- Embedded computation at or near sensor node
- Sensor suites
- Virtual sensing

SMART SYSTEMS AND PARTS

- Embedded sensors
- Printed sensors
- Smart materials and coatings
- Adaptive/Self Organizing sensor networks

I4GEN Sensor Maturity Model

New Sensor Technologies & Detection Techniques

Advanced Sensing Techniques

- Novel approaches to sensing (e.g., high sensitivity or selectivity, broad sensing range, low drift, high signal to noise ratio and low power requirements)

Sensors for Harsh Environments

- Materials that can withstand high temperatures and pressures
- Designs for dust, steam and vibration

Sensors for Reducing Manual Data Collection and Field Testing

- Lower cost sensors that enable increase in data collected and provide information to assist in prioritizing manual/field testing

Challenges for Sensor Deployment

- Cost of Installation
 - Wireless vs Wired Infrastructure
- Cyber security
 - Of devices
 - Of the network
- Maintenance
 - Of sensors
 - Data quality
- Data Utilization
 - Data and information management
 - Scalable infrastructure

Reference Data Architecture – For Analytics

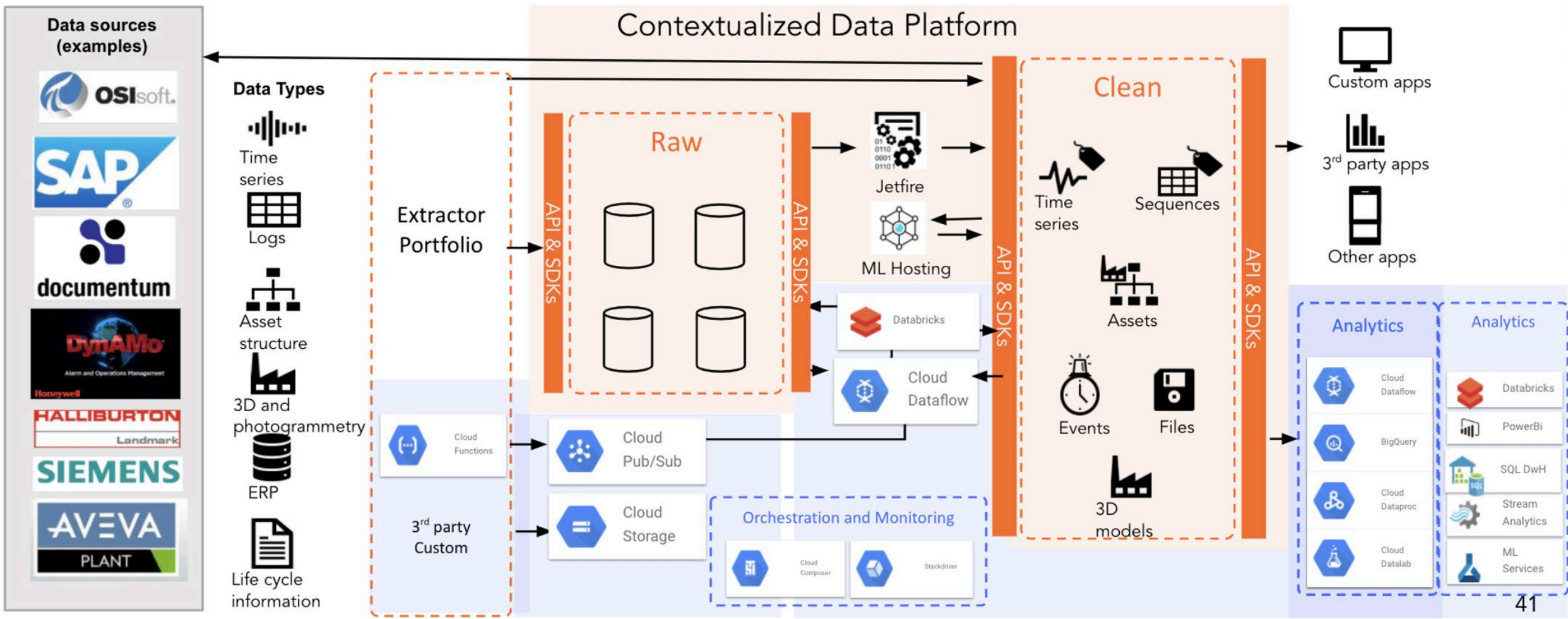

Wind Turbine Data: Events and Streaming Applications

[3002016450](#) – Specifications and best practices

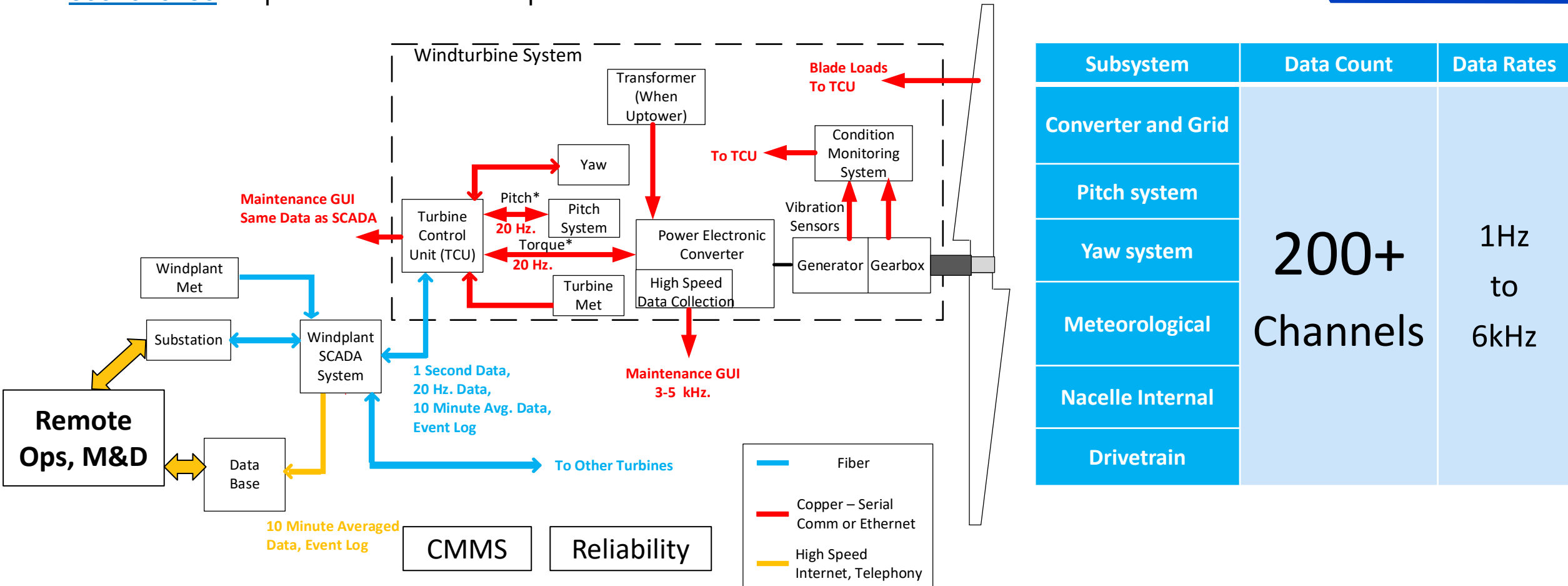

Data-to-Knowledge Underutilized for Reducing O&M Cost

Digital Transformation Renewables Applications

- Critical data stream identification
- Central remote monitoring *and control*
- Proactive maintenance
- Production assurance and enhancement
- Benchmarking, continuous improvement

Reliability Benchmarks/Projections, Health, Condition-Based Maintenance

Gearbox, Generator

Blades

Main Bearing, Pitch System, Yaw

Other Systems

Production Efficiency Monitoring and Improvements

Yaw and Direction Calibrations

Pitch and Imbalance Assessment

Wake – Opportunity Assessments

Wake Reduction

Wake Steering?

Site Layout Optimizations

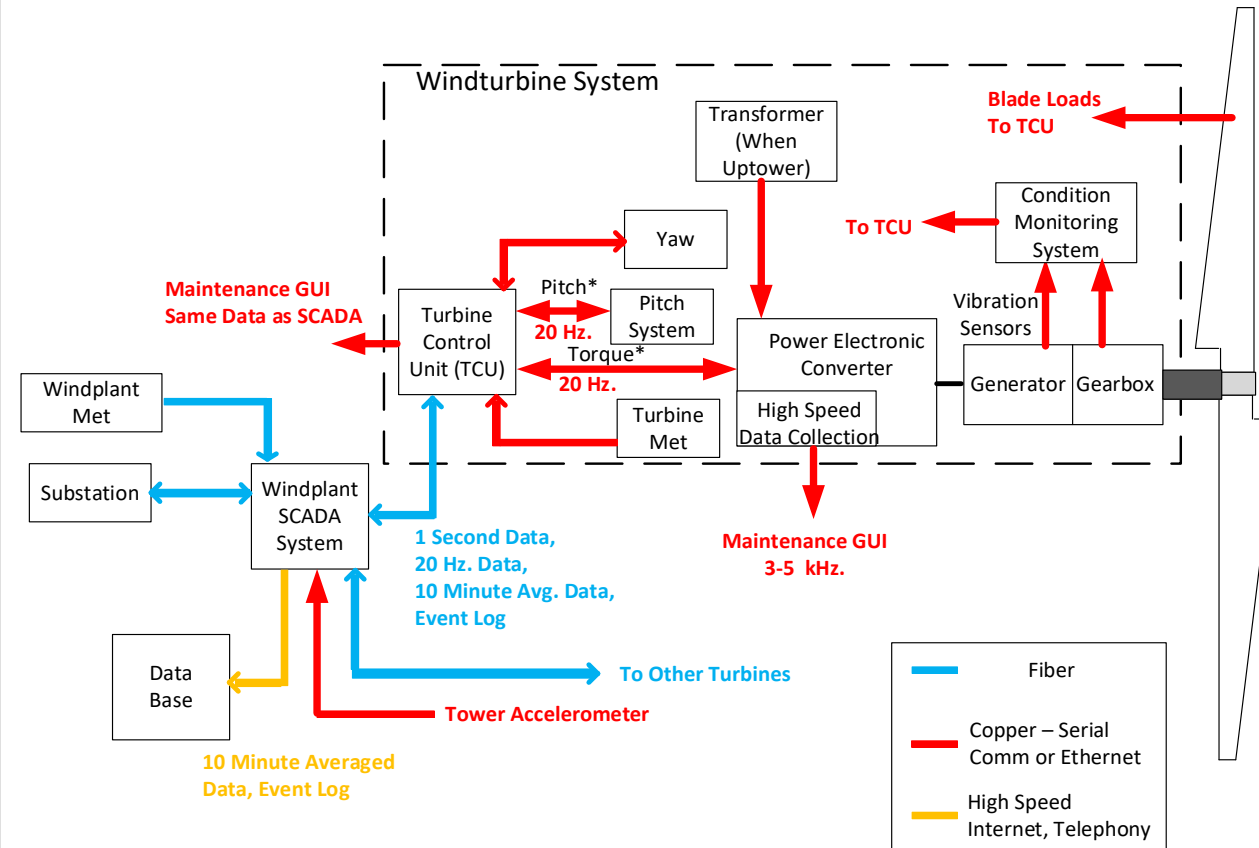

HOW to obtain data efficiently, securely, two-way and meet all needs?

Decarbonization

Digitalization

Decentralization

Value in a transformed energy system will come through Integration
Interdependencies will increase and systems thinking will rule
Capital investments become more challenging to justify

New solutions have to prove immediate and obvious value



EPRI 50th
ANNIVERSARY